

LOC	DIST	REVISIONS			
P	LTR	DESCRIPTION	DATE	DWN	APVD
AF	50	H	REVISED PER ECR-06-010423	22SEP06	HMR KR

- 1 CONTINUOUS STRIP ON REELS WITH TERMINALS LOCATED ON 8.38 ± 0.08 [$.330 \pm .003$] CENTERS
- 2 SLOT ACCEPTS $0.25-0.32\text{mm}$ [#30-#28] AWG COPPER MAGNET WIRE. TWO WIRES OF THE SAME SIZE MAX PER SLOT
- 3 IDENTIFICATION NUMBER 6 FOR THE MAGNET WIRE SLOT SIZE
- 4 0.25 [.010] MAX CARRIER CUT-OFF TABS.

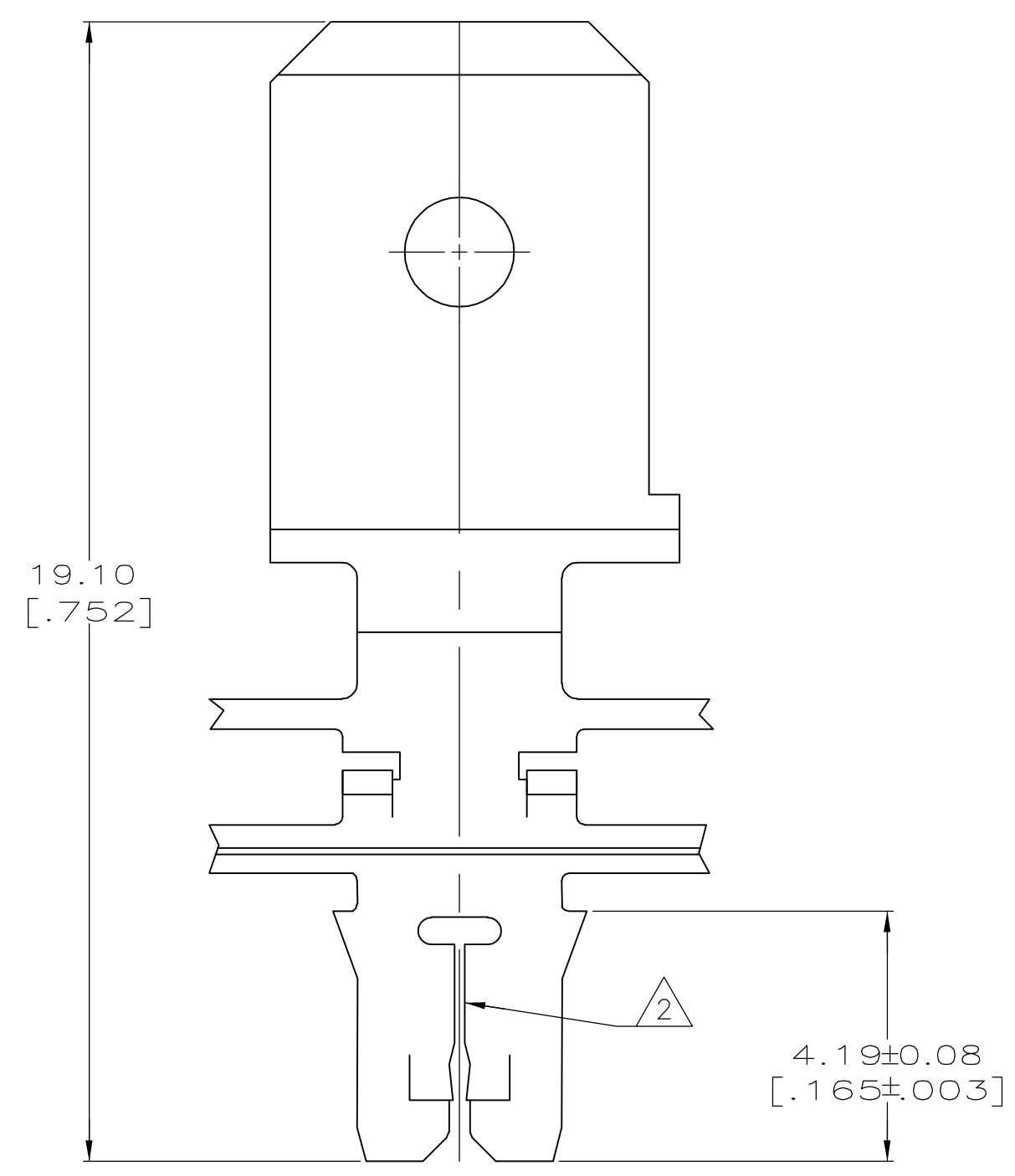
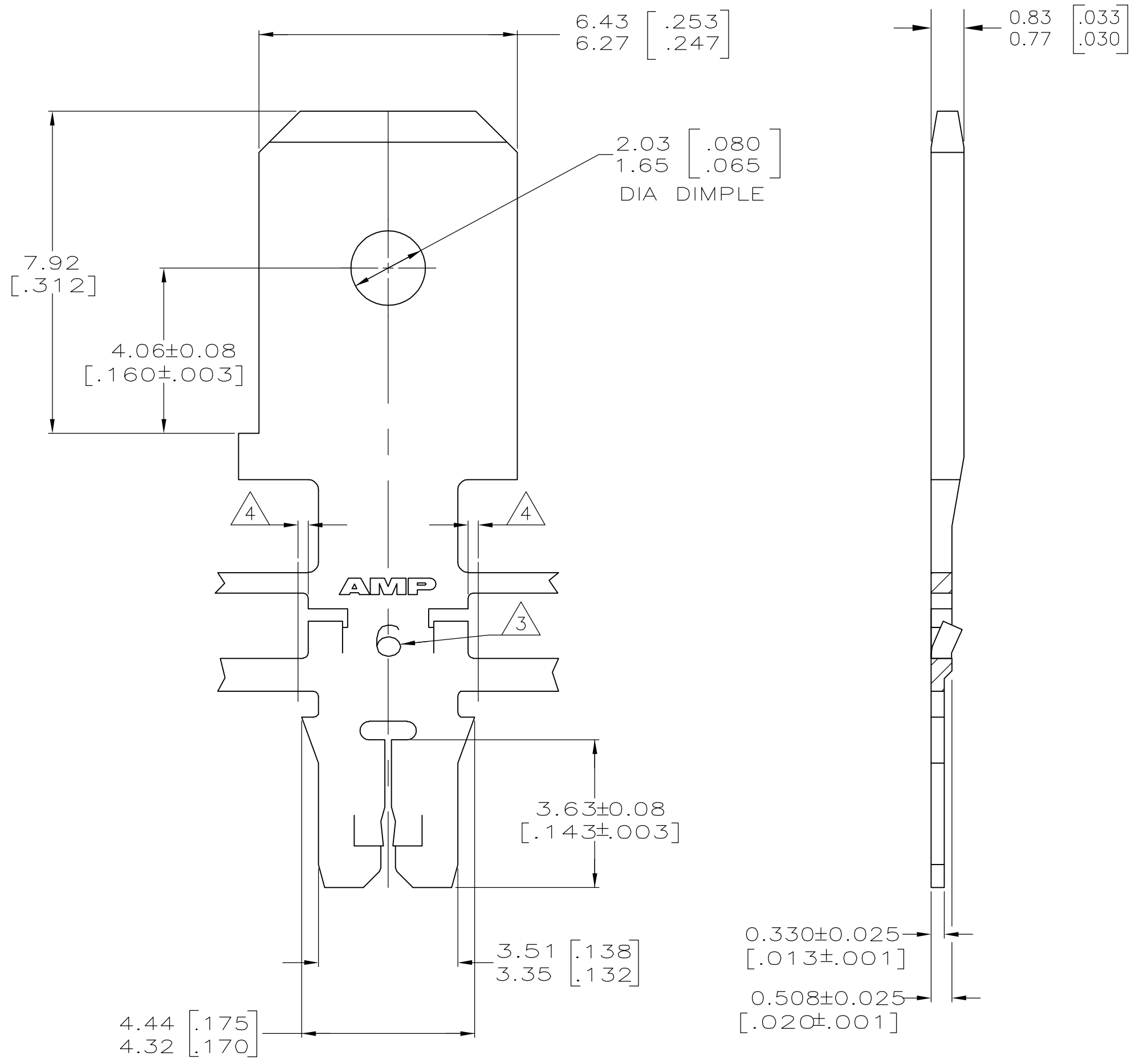

OBsolete	082 PRE-MILLED BRASS	63743-2
	4M PRE-MILLED BRASS	63743-1
	MATERIAL	PART NO

THIS DRAWING IS A CONTROLLED DOCUMENT.		DWN L.A.MAYER 9-1-93	Tyco Electronics Corporation	
DIMENSIONS: mm [INCHES]		CHK M.S. FEHER 9-1-93	Harrisburg, PA 17105-3608	
TOLERANCES UNLESS OTHERWISE SPECIFIED:		APVD A.HUNT III 9-1-93	NAME	
0 PLC ± -	1 PLC ± -	TAB, 6.35 [.250] FASTON,™		
2 PLC ± 0.13 [.005]	3 PLC ± -	MAG-MATE™ Slim Line		
4 PLC ± -	ANGLES ± -	PRODUCT SPEC 108-1484	SIZE A2	CAGE CODE 00779
MATERIAL SEE TABLE	FINISH 0.002032 [.000080] MIN TIN PLATE	APPLICATION SPEC 114-2140	DRAWING NO G-63743	RESTRICTED TO -
CUSTOMER DRAWING		WEIGHT -	SCALE 10:1	SHEET 1 of 1
		REV H		